

burda style

Instructions for Download

The details for the individual sizes of a pattern are listed one after another in the instructions, separated by hyphens. If just one detail is given, it applies to all sizes.

001 Dress ••

Sizes 34, 36, 38, 40, 42, 44
Length from waist 60 cm
3/4 sleeve approx. 48 cm long

You will need:

Silk linen, 140 cm wide: 2.20 – 2.20 – 2.20 – 2.20 – 2.40 – 2.40 m.
Vilene G 785.

1 in-seam zip, 60 cm long, and special presser foot.
Sewing thread.

Fabric recommendation: lightweight dress fabrics.

Paper pattern:

Cut out pattern in the required size.

Seam and hem allowances:

Seams & edges 1.5 cm, hem 4 cm, sleeve hems 3 cm.

Cutting out:

- 1 Centre-front section to fabric fold 1x
- 2 Side-front section 2x
- 3 Back 2x
- 4 Side-front skirt panel 2x
- 5 Back skirt panel 2x
- 6 Front facing to fabric fold 1x
- 7 Back facing 2x
- 8 Sleeve 2x

Interfacing see grey area in cutting-out plan.

Sewing:

- Sew darts. Iron bust darts downwards and back darts to the centre.
- Stitch side-front skirt panels to side-front sections. Stitch back skirt panels to back sections. Press seam allowances apart.
- Sew the pleats on the centre-front section from the inside, from the top edge down to the arrow symbol in each case; baste underneath. Fold pleats in the direction of the arrow and press; baste at the top. Place side-front sections and side-front skirt panels right sides facing on the center-front section and

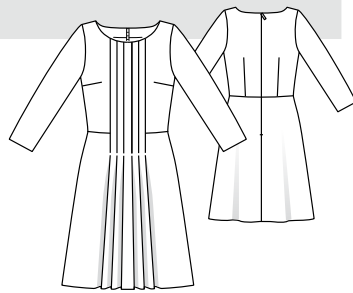

Pattern pieces 1 to 8

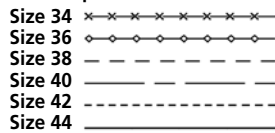

stitch together the joining and pleat-fold lines from the top up to the cross line; baste the rest of the pleats. Stitch inside pleat seams up to approx. 10 cm above the hemline. Fold pleats towards the centre front. Press pleats.

■ In-seam zip, centre-back seam:

Open zip and flatten the coil with your thumbnail so that the seam line between the tape and the coil can be seen. Place the right half of the open zip top-side-to-right-side on the right edge of the opening. Distance from tape edge to seam-allowance edge, 5 mm (= seam-allowance width minus 1cm tape width). The teeth begin on the marked neckline. Pin the top end of the zip on the seam-allowance edge. Lower the presser foot onto the zip so that the coil lies in the groove just to the right of the needle(1). Sew the zip in place, starting at the top and stopping just short of the

marked opening. Close the zip. Place the second zip tape with its top side on the edge of the left back opening and pin in place at the top. Open the zip again. Lower the presser foot onto the top end of the zip so that the coil lies in the groove just to the left of the needle (2). Stitch the zip in place. Sew the centre-back seam, starting at the bottom and working up to the zip. Press seam allowances open and neaten.

■ **Shoulder seams:** Place back sections on front section with right sides facing; pin shoulder seams. Stitch. Press seam allowances open

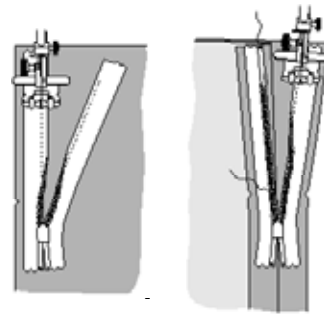

and neaten.

■ **Neckline:** Stitch shoulder seams on facing. Press seam allowances open. Neaten inside edge of facing. Pin facing to neckline right sides together. Fold back facing ends on zip opening approx. 5 mm in front of the marked seam line and pin at neckline. Place opening allowances of dress outwards and pin above the facing. Stitch along the neckline edge. Trim seam allowances; notch in the curves right up to the straight stitching. Turn facing and back opening allowances inwards. Sew the facing onto the zip tapes and the se-

am allowances of the shoulder seams.

■ **Side seams:** Place back section on front section with right sides together and pin side seams. Stitch together. Press seam allowances open and neaten.

■ **Sleeves:** To gather the sleeve heads, sew from • to • on both sides of the marked seam line with the largest stitch setting. Do not pull lower threads of the stitch lines yet.

Fold sleeves lengthways and sew sleeve seams. Press seam allowances apart and neaten. Neaten hem allowances; iron over inwards and sew on loosely by hand. With right sides facing, pin sleeves in the lower area of the armholes only at first; Sleeve seams and side seams as well as cross marks 8 of sleeve and front section meet up. Next, pin the shoulder marking (cross mark) of the sleeve heads on the shoulder seams. Only now gather the sleeve heads using the lower threads of the 'gathering' stitching, until the sleeves fit in the armholes. Pin sleeve heads, distributing the gathered circumference evenly. Baste and sew in sleeves from the sleeve side. Fold seam allowances towards sleeve.

■ Iron hem allowance inwards and sew on by hand. Stitch remaining pleat seams up to the hem edge. Turn under bottom ends of seam allowances at an angle and stitch together. Re-iron pleat folds on the hem.

Cutting-out plans

Silk linen, 140 cm wide

Sizes 34 to 40

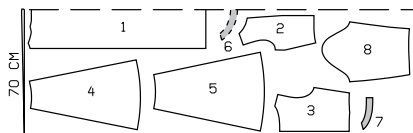

Sizes 42 and 44

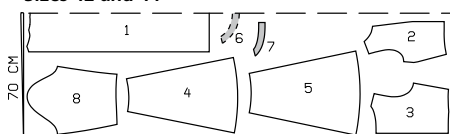

Cut out from a double layer of fabric, right sides together.

BURDA SIZE CHART

WOMEN'S SIZES for a height of 168 cm

Size	cm	34	36	38	40	42	44	46	48	50	52
Bust	cm	80	84	88	92	96	100	104	110	116	122
Waist	cm	62	66	70	74	78	82	86	92	98	104
Hips	cm	86	90	94	98	102	106	110	116	122	128
Front waist length	cm	43	44	45	46	47	48	49	50	51	52
Bust depth	cm	25	26	27	28	29	30	31	32	33	34
Back length	cm	41	41	42	42	43	43	44	44	45	45
Back width	cm	33,5	34,5	35,5	36,5	37,5	38,5	39,5	41	42,5	44
Shoulder width	cm	12	12	12	13	13	13	13	14	14	14
Sleeve length	cm	59	59	60	60	61	61	61	61	62	62
Upper arm	cm	26	27	28	29	30	31	32	34	36	38
Neck	cm	34	35	36	37	38	39	40	41	42	43

Copyright 2010 by Verlag Aenne Burda GmbH & Co. KG, Am Kestendamm 2, D-77652 Offenburg, Germany.

All models, pattern pieces and drawings are protected by copyright. The sewing of these projects for commercial purposes is prohibited. The publishers accept no liability for damages arising from improper handling of the pattern or materials, incorrect execution of the tips and instructions, or improper use of the models.